

# VACUUM CLEANING ATTACHMENTS AND ACCESSORIES

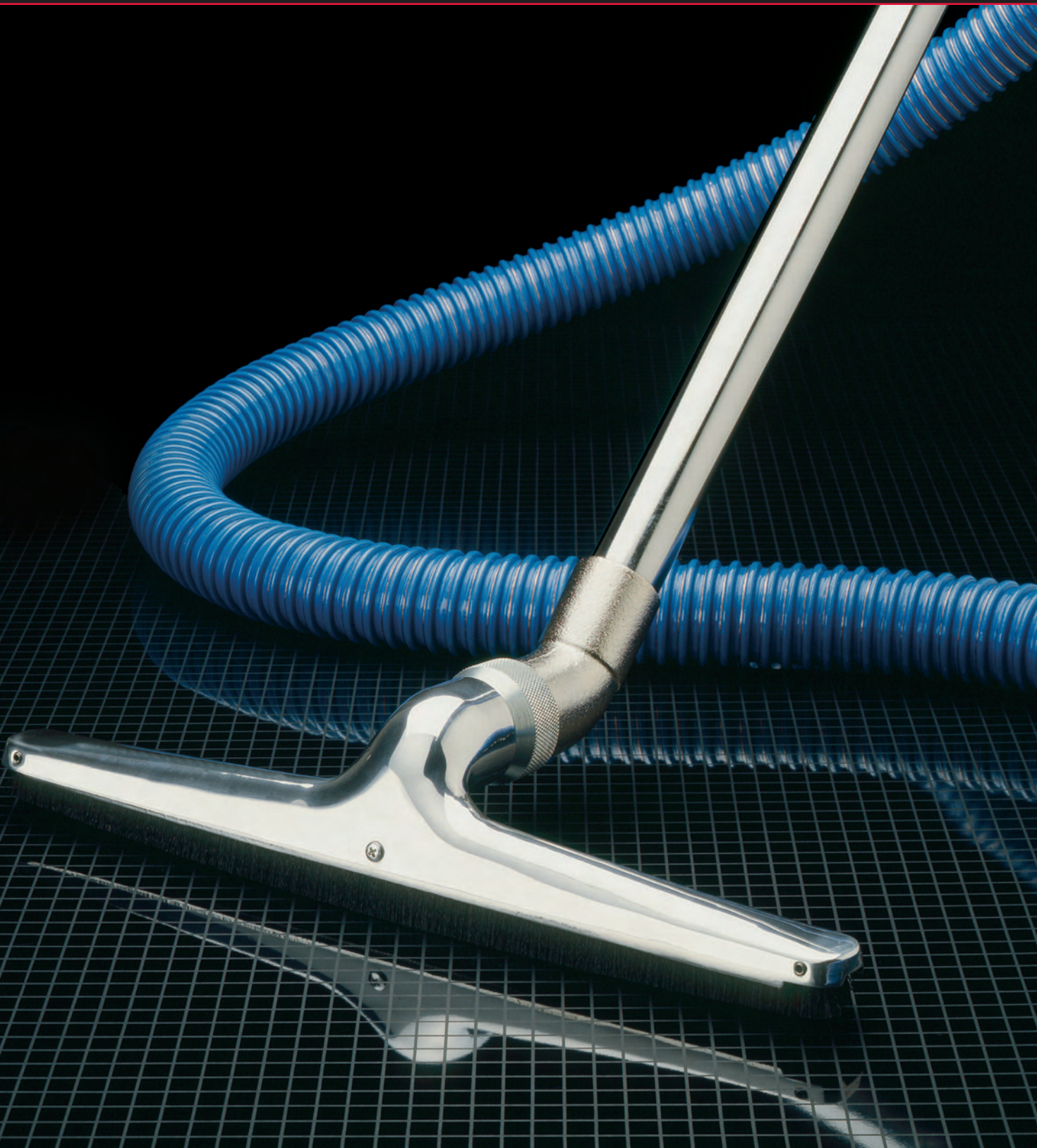

# ASSEMBLY INSTRUCTIONS

## Male Coupling to Inlet Valve

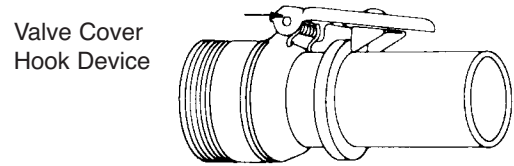
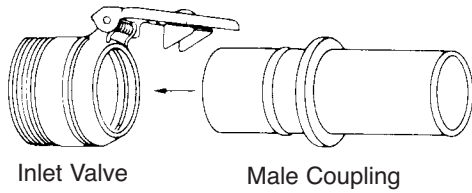

## Male Hose Coupling to Female Coupling

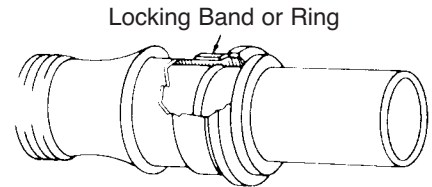
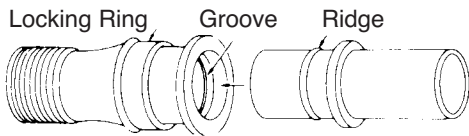

## Grooved Neck to Knurled Nut Connector

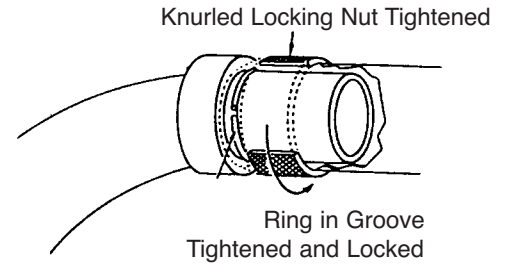
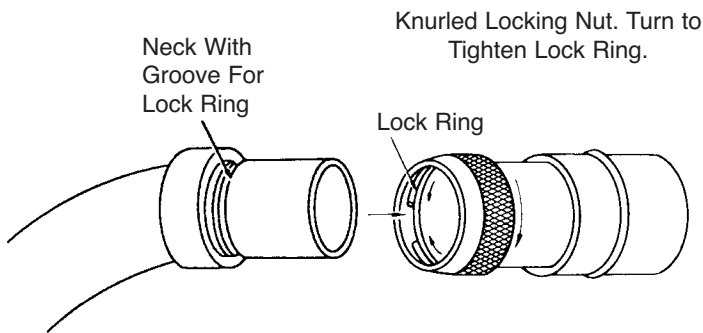

## Typical Floor Tool and Elbow Joint Assembly

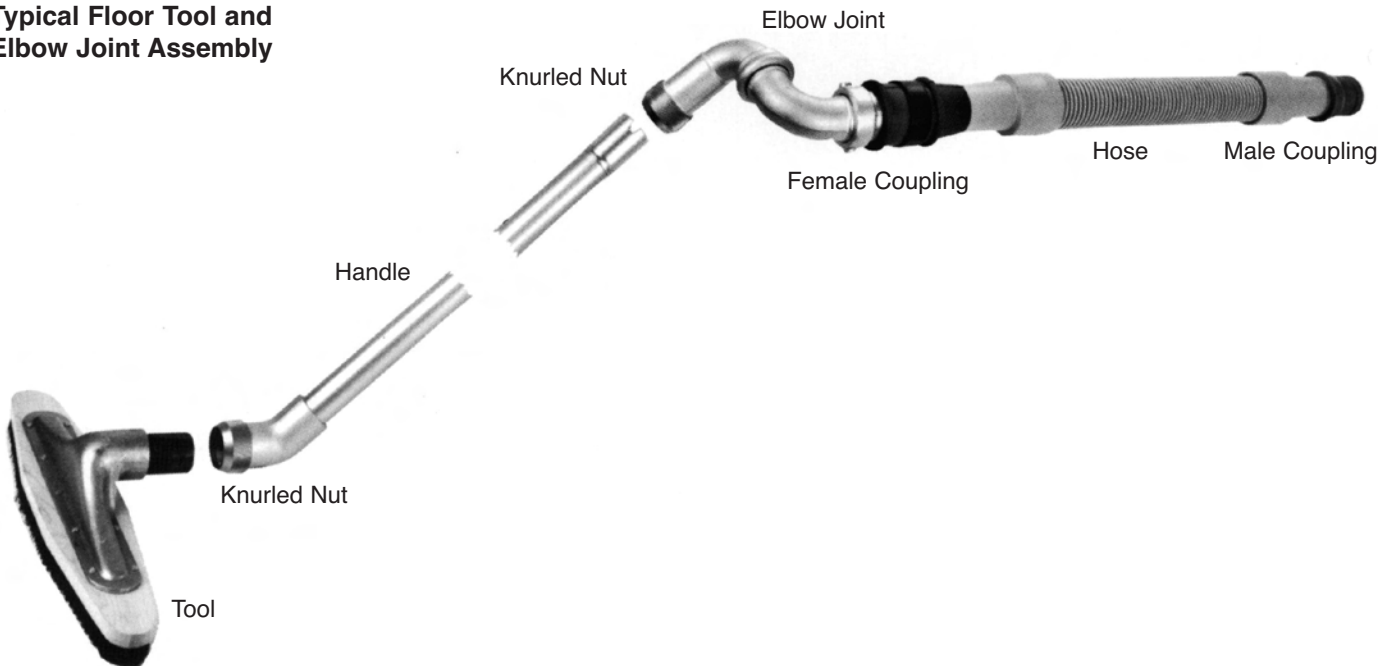

# TOOLS

Spencer tools are made of durable materials and are designed for convenience and effectiveness with openings in correct proportion to the rest of the system. All wearing surfaces are renewable.

Floor tools are available in three basic sizes.

## 12" Wide

For cleaning congested areas, around chairs, or in narrow areas where a large tool would be awkward to use.

## 14-15" Wide

The most practical and common for general service.

## 20" Wide

Designed for use in large unobstructed areas such as corridors, auditoriums, or gymnasiums.

Vacuum tools with brushes or bristles are used when it is necessary to dislodge material before it is picked up. Three types of brush material are used by Spencer.

### HORSEHAIR

**Soft** – Cut from the mane or tail. A gentle brush best suited for smooth surfaces or walls.

### NYLON BRISTLES

**Medium Stiffness** – A popular brush material, man made synthetic fiber recommended for general service, long life, chemical resistant, good memory.

### TAMPICO FIBERS

**Stiff** – A common high quality fiber bristle derived from plants. Use for heavy brush service, fair memory, heat resistant.

Brush material is designated in item description.

Note: Part numbers are listed first. The old catalog number is listed in parentheses.

Note: Replacement parts available for most tools.  
*Replacement part numbers are listed in blue italic.*

## 1 1/2" BARE FLOOR TOOLS

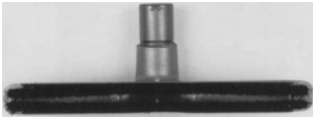
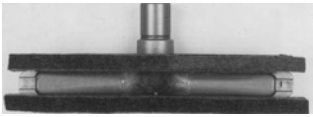
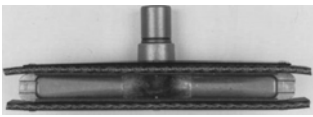

*Bare Floor Tools are designed for use at the end of a wand.*

		12" Wide	15" Wide	20" Wide
	<b>BRUSH STRIPS</b> – Nylon for sticky dust or rough uneven surfaces. <i>*Replacement strip</i>	<b>VTL90019</b> (1210) .88 lb. <i>BRS90003</i>	<b>VTL90018</b> (1510) 1 lb. <i>BRS90004</i>	<b>VTL90020</b> (2010) 1.50 lb. <i>SVT90027</i>
	<b>FELT BLADES</b> – For polished floors, wood, linoleum, and other smooth surfaces. <i>*Replacement strip</i>	<b>VTL90021</b> (1211) .94 lb. <i>SVT90005</i>	<b>VTL90022</b> (1511) 1.13 lb. <i>SVT90006</i>	<b>VTL90023</b> (2011) 1.63 lb. <i>SVT90007</i>
	<b>RUBBERIZED FABRIC</b> – For unfinished wood floors and rough surfaces. Also liquid removal from rough surfaces. <i>*Replacement strip</i>	<b>VTL90024</b> (1212) 1.44 lb. <i>SVT90002</i>	<b>VTL90025</b> (1512) 1.75 lb. <i>SVT90003</i>	<b>VTL90026</b> (2012) 2.2 lb. <i>SVT90004</i>

*\*Quantity (2) required.*

# 1 1/2" BARE FLOOR TOOLS

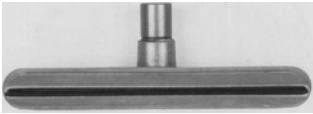
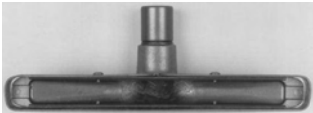
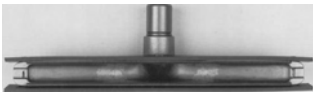
Bare floor tools are designed for use at the end of a wand.  
 Replacement part numbers are listed in blue italic.  
 \*Quantity (2) required.

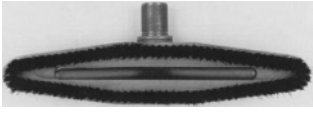
		12" Wide	15" Wide	20" Wide
	<b>SQUEEGEE</b> – Pliable rubber blade for liquid recovery.  <i>Replacement blade black</i> <i>Replacement blade white</i> <i>Replacement bumper</i>	<b>VTL90027</b> (1213) 2.19 lb. <i>BLV90000</i> <i>BLV90002</i> <i>BUF90004</i>	<b>VTL90028</b> (1513) 2.63 lb. <i>BLV90001</i> <i>BLV90003</i> <i>BUF90002</i>	—
	<b>STEEL BLADES</b> – For scraping or severe service on rough abrasive floors as in industrial plants. <i>*Replacement blade</i>	<b>VTL90029</b> (1214) 1.56 lb.  <i>SVT90008</i>	<b>VTL90030</b> (1514) 1.88 lb.  <i>SVT90009</i>	<b>VTL90031</b> (2014) 2.44 lb.  <i>SVT90010</i>
	<b>PLASTIC BLADES</b> – For clean room and food handling applications. <i>*Replacement blade</i>	<b>VTL90033</b> (1215) .88 lb. <i>SVT90000</i>	<b>VTL90032</b> (1515) 1.00 lb. <i>SVT90001</i>	—
	<b>ELEVATED BLADES WITH WHEELS</b> – For severe service and mobility on rough industrial plant floors. <i>*Replacement wheel</i>	<b>VTL90036</b> (1216) 1.88 lb.  <i>WHL90006</i>	<b>VTL90035</b> (1516) 2.25 lb.  <i>WHL90006</i>	<b>VTL90037</b> (2016) 2.88 lb.  <i>WHL90006</i>
	<b>CEMENT FLOOR TOOL</b> – Tampico bristles for loosening sticky materials on rough surfaces or unfinished cement floors. <i>Replacement brush (polypropylene base)</i>	—	<b>VTL90017</b> (1290) 1.5 lb.  <i>BRS90030</i>	—

## 4" GULPER WITH WAND – VTL90047

(1786)  
 4.13 lb.

Aluminum. For removing large accumulations of litter, complete with permanently attached wand. Connects directly into 1 1/2" female hose coupling, elbow joint or hose connector.



# 1 1/2" HAND TOOLS

Hand tools attach directly to the female hose coupling.

\*May also be used with wall handles, hose connectors, or gooseneck.

Replacement part numbers are listed in blue italic.



**8" HAND BRUSH** – Nylon. Designed for hand cleaning of large flat surfaces like shelves and ledges.

*Replacement brush*  
*Replacement bumper*

**VTL90039**  
(920)  
1.13 lb.  
*BRS90007*  
*BUF90001*



**4" ROUND BRUSH** – Nylon with polypropylene base. Recommended for general cleaning.

*Replacement brush/base*  
*Replacement bumper*

**VTL90040\***  
(1270)  
1.50 lb.  
*BRS90029*  
*BUF90000*



**4" ROUND BRUSH** – Nylon with hose swivel and polypropylene base. Recommended for general cleaning.

*Replacement brush/base*  
*Replacement bumper*

**VTL90042**  
(1811)  
1.25 lb.  
*BRS90029*  
*BUF90000*



**CORNER & CREVICE** – Anodized Aluminum. Designed for difficult to reach areas. Recommended for heavy duty surface.

**VTL90002**  
(1471)  
.63 lb.



**CORNER & CREVICE** – Zinc Plated Steel. Designed for difficult to reach areas. Recommended for severe duty surface.

**VTL90001**  
(1472)  
.88 lb.



**6" HAND TOOL** – For cleaning shelves, ledges or upholstered furniture.

**VTL90052\***  
(2975)  
1.13 lb.



**6" HAND TOOL** – With nylon brush for removing sticky dirt.

*Replacement brush*

**VTL90053\***  
(2976)  
1.25 lb.  
*BRS90010*

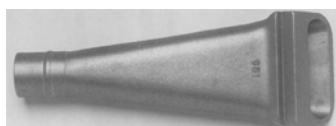

**4" GULPER** – Aluminum. For removing large accumulations of bulky litter.

**BOV90010**  
(1785)  
1.75 lb.

## 1 1/2" HAND TOOLS

Hand tools attach directly to the female hose coupling.



**GULPER** – Rubber. For easy cleaning around machinery. Full bore for large accumulation of material pickup.

**VTL90050**  
(2002)  
.88 lb.



**SUMP TANK** – Steel. Liquid-handling—has 3/8 inch bleeder hole to speed pick-up. Recommended for use with Spencer Sump-Vac®.

**VTL90054**  
(2510)  
2.13 lb.



**TAPERED NOZZLE** – Rubber. Oil resistant. Designed for cleaning holes or for use around motors or other electrical equipment. Also used for blowing applications.

**VTL90051**  
(2515)  
.44 lb.

## 1 1/2" CARPET TOOLS

Carpet tools are used at the end of a wand.  
Replacement part numbers are listed in blue italic.

		12" Wide	15" Wide
	<p><b>NARROW SLOT</b> – With rubber bumper and plain metal shoe. Most effective for deep cleaning—short or medium pile. Also effective for drawing excessive water from carpet. <i>Replacement shoe</i> <i>Replacement bumper</i></p>	<p><b>VTL90009</b> (1200) 1.00 lb.</p>	<p><b>VTL90010</b> (1500) 1.25 lb.</p>
		<p><i>SHV90002</i> <i>BUF90003</i></p>	<p><i>SHV90006</i> <i>BUF90005</i></p>
	<p><b>WIDE SLOT</b> – With rubber bumper and plain metal shoe. General cleaning of medium to heavy pile. Allows for passage of large debris. <i>Replacement shoe</i> <i>Replacement bumper</i></p>	<p><b>VTL90011</b> (1201) 1.00 lb.</p>	<p><b>VTL90012</b> (1501) 1.25 lb.</p>
		<p><i>SHV90000</i> <i>BUF90003</i></p>	<p><i>SHV90007</i> <i>BUF90005</i></p>
	<p><b>WIDE VENTS</b> – With rubber bumper and vented shoe for increased surface flow. For wool and synthetic shag. Especially useful when threads and lint are prevalent. <i>Replacement shoe</i> <i>Replacement bumper</i></p>	<p><b>VTL90013</b> (1202) 1.00 lb.</p>	<p><b>VTL90014</b> (1502) 1.25 lb.</p>
		<p><i>SHV90003</i> <i>BUF90003</i></p>	<p><i>SHV90009</i> <i>BUF90005</i></p>

# 1½" CARPET TOOLS

Carpet tools are used at the end of a wand.  
Replacement part numbers are listed in blue italic.

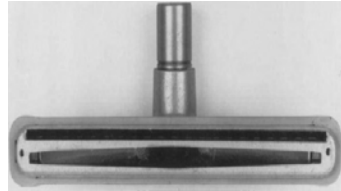

**BRUSH INSERT** – With rubber bumper and nylon bristle strip. For imbedded dirt on indoor/outdoor or other short pile carpets.  
*Replacement shoe*  
*Replacement bumper*

**12" Wide**

**15" Wide**

**VTL90015**  
(1203)  
1.19 lb.

**VTL90016**  
(1503)  
1.44 lb.

*SHV90001*  
*BUF90003*

*SHV90008*  
*BUF90005*

# 1½" WALL AND OVERHEAD TOOLS

Wall and overhead tools are designed for use with wall handles or hose connectors.  
For additional flexibility use 45° gooseneck elbow with these tools.  
Replacement part numbers are listed in blue italic.

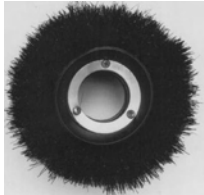

**4" ROUND BRUSH** – Nylon. Recommended for general cleaning of mouldings and irregular surfaces in small areas.  
*Replacement brush*  
*Replacement bumper*

**VTL90044**  
(930)  
.75 lb.

*BRS90029*  
*BUF90000*



**6" PIPE BRUSH** – Nylon bristle strip in center of slot. Allows dust to be loosened and drawn away without falling to the floor.  
*Replacement brush*

**VTL90055**  
(2040)  
1.13 lb.

*BRS90023*

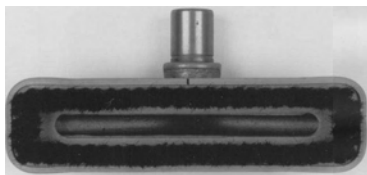

**WALL BRUSH** – Horsehair. Recommended for paneled or painted walls or any smooth surface.  
*Replacement brush*

**10½" Wide**

**15" Wide**

**VTL90068**  
(1990)  
1.50 lb.  
*BRS90015*

**VTL90070**  
(1615)  
1.75 lb.  
*BRS90013*

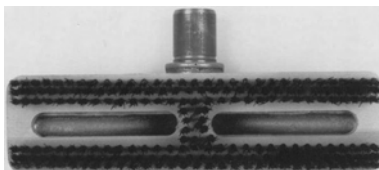

**PIPE AND LEDGE BRUSH** – Nylon. Designed for overhead cleaning of pipes and ledges with heavy dust accumulation.  
*Replacement brush*

**6" Wide**

**11" Wide**

**VTL90059**  
(1865)  
1.25 lb.

**VTL90060**  
(1860)  
1.50 lb.

*BRS90011*

*BRS90012*

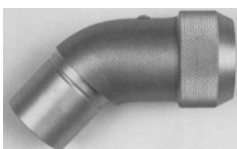

**45° GOOSENECK ELBOW** – Aluminum. Connects wall handle or hose connector to wall or overhead tools.

**EVT90008**  
.28 lb.

# 1 1/2" PLASTIC TOOLS

## FLOOR TOOLS

These high impact molded plastic floor tools are used at the end of a wand.

Replacement part numbers are listed in blue italic.

\*Quantity (2) required.

\*\*Quantity (4) required.



14" Wide

	<b>SCALLOPED VENTS</b> – With rubber bumper. Most effective on short and medium pile carpets. <i>Replacement bumper</i>	<b>VTL90067</b> .88 lb. <i>BUF90009</i>
	<b>NYLON BRISTLES</b> – For cleaning sticky dust from hard floors or rough, uneven surfaces. <i>Replacement brush</i>	<b>VTL90064</b> 1.00 lb. <i>BRS90019</i>
	<b>TAMPICO BRISTLES</b> – For removing caked dirt or sticky material. <i>Replacement brush</i>	<b>VTL90065</b> 1.00 lb. <i>BRS90020</i>
	<b>FELT BLADES</b> – For cleaning polished wood, linoleum, or other smooth surfaces. <i>*Replacement blade</i>	<b>VTL90062</b> 1.00 lb. <i>SVT90022</i>
	<b>FIBER BLADES</b> – For cleaning unfinished wood, rough or abrasive surfaces. <i>*Replacement blade</i>	<b>VTL90063</b> 1.25 lb. <i>SVT90023</i>
	<b>DOUBLE-BLADED SQUEEGEE</b> – For liquid recovery. Two neoprene rubber blades. <i>*Replacement blade – neoprene</i> <i>**Replacement metal holder</i>	<b>VTL90066</b> 1.58 lb. <i>BLV90004</i> <i>SVT90024</i>

## HAND TOOLS

These tools attach directly to the female hose coupling.

Replacement part numbers are listed in blue italic.

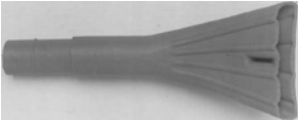
	<b>CORNER &amp; CREVICE</b> – For cleaning narrow and difficult to reach areas.	<b>VTL90000</b> (1470) .56 lb.
	<b>5" UPHOLSTERY</b> – For fabrics and small areas with slide-on nylon brush end. <i>Replacement brush</i>	<b>VTL90061</b> .50 lb. <i>BRS90021</i>
	<i>This tool is designed to connect directly to a 1 1/2" female hose coupling.</i> <b>4 1/2" AUTO CLEANING TOOL with BUSHING</b> – Designed with narrow slot to reach in between seat and consoles.	<b>VTL90099</b> .32 lb.
	<i>This tool is designed to fit directly into the inside diameter of a 1 1/2" hose with cuff.</i> <b>4 1/2" AUTO CLEANING TOOL</b> – Tool design same as VTL90099 without bushing.	<b>VTL90085</b> .31 lb.



# 1 1/2" WANDS

Effective curves and a knurled locking nut allow the operator to reach normally inaccessible areas without moving obstacles. These wands are designed for both wet and dry service.

Two standard lengths of 52" and 58" are available to suit application or operator preference.

**HDL90036**

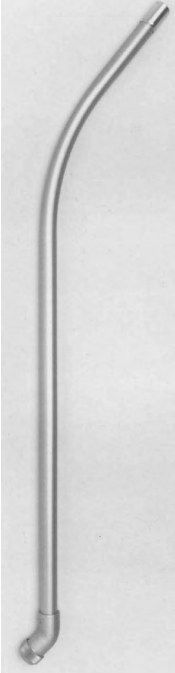

**HDL90035**



**HDL90038**



**52" CHROME PLATED** – Steel. To be used with any elbow joint, hose connector or elbow connector. Heavy duty industrial service or for cleaning congested areas.

**HDL90036**  
(1297S)  
2.50 lb.

**58" CHROME PLATED** – Steel. To be used with any elbow joint, hose connector or elbow connector. Heavy duty service or for congested areas.

**HDL90035**  
(1297)  
2.75 lb.

**58" CHROME PLATED** – Steel. Connects directly to a 1 1/2" female hose coupling or any elbow joint.

**HDL90038**  
3.50 lb.

**52" SATIN ANODIZED** – Aluminum. To be used with nickel-plated elbow joint, elbow connector, or hose connector. Lighter in weight—used for general service.

**HDL90033**  
(1295S)  
1.00 lb.

**58" SATIN ANODIZED** – Aluminum. To be used with any nickel-plated elbow joint, hose connector, or elbow connector. Lighter in weight—used for general service.

**HDL90034**  
(1295)  
1.13 lb.

**58" SATIN ANODIZED** – Aluminum. Connects directly to a 1 1/2" female hose coupling or any nickel-plated elbow joint.

**HDL90037**  
(1298)  
1.63 lb.

**POWER BRUSH (VTL90089)** Pictured 52" anodized aluminum floor handle. Use with female hose coupling.

**HDL90062**  
10.00 lb.



**HDL90062**

# 1 1/2" WALL HANDLES

Light weight aluminum wall handles are used for overhead wall and pipe cleaning, or difficult to reach areas. Two- and four-foot sections may be combined for the most convenient length. Attractive satin

anodizing prevents oxidation. All wall handles must be used in conjunction with an elbow joint, elbow connector, or hose connector (see pages 9 and 10).

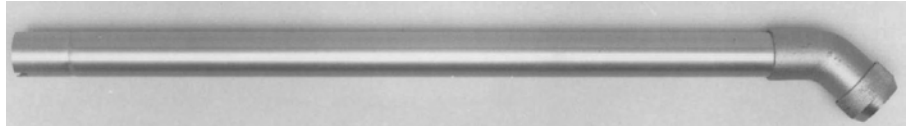

**TWO-FOOT EXTENSION –**  
With 45° nickel-plated elbow and knurled locking nut.

**HDL90040**  
(1370)  
.75 lb.



**FOUR-FOOT STRAIGHT EXTENSION –**  
With knurled locking nut.

**HDL90013**  
(2000)  
1.00 lb.

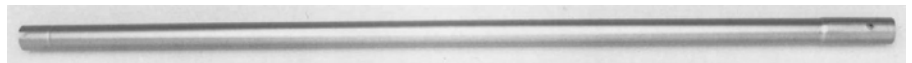

**FOUR-FOOT EXTENSION –**  
Slip-fit design to be used with either the HDL90040 or HDL90013 wall handles. (Does not accept tool directly.)

**HDL90019**  
(1365)  
.75 lb.

# CONCENTRIC TUBE GULPER TOOL

Note:  
This end slides directly into bare (no coupling) hose and uses hose clamp.

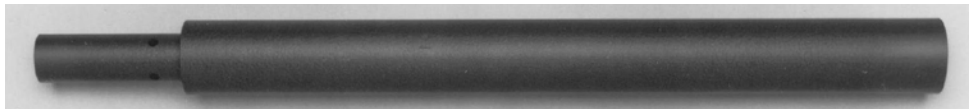

**CONCENTRIC TUBE GULPER TOOL –**

Carbon Steel painted blue. Designed with air bleed system allowing tool end to be buried in material being conveyed. Slides directly into hose i.d. sizes 1 1/2", 2", 2 1/2", 3", 3 1/2", 4". Available in other materials of construction. Consult factory.

Size	P/N	Size	P/N
1 1/2"	VTL90100	3"	VTL90104
2"	VTL90102	3 1/2"	VTL90105
2 1/2"	VTL90103	4"	VTL90106

# 1 1/2" ELBOW JOINTS

Elbow joints are designed for connecting hose to a wand or wall handle. These uniquely designed elbow joints combine a ball bearing swivel and a knurled

locking nut. They provide the ultimate connection between hose and handle.

- Prevents hose twisting.
- Allows hose to hang freely.
- Reduces operator effort.
- Provides operator with handlegrip.
- Reduces hose wear at point of maximum stress.
- Shut-off valve conserves energy.



**NICKEL-PLATED MALLEABLE IRON** – With shut-off valve, hose swivel and locking nut— for heavy duty service.

**EVT90003**  
(1255)  
2.50 lb.

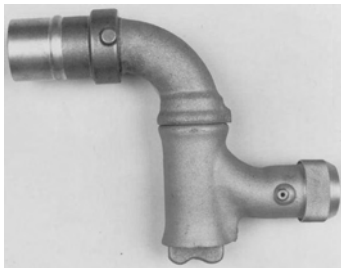

**NICKEL-PLATED ALUMINUM** – With shut-off valve, hose swivel and locking nut—for general service.

**EVT90002**  
(1380)  
1.50 lb.



**NICKEL-PLATED ALUMINUM** – With locking nut— for general service.

**ENJ90001**  
(1660)  
.88 lb.



**NICKEL-PLATED ALUMINUM** – With hose swivel and locking nut—for general service.

**ENJ90002**  
(1661)  
1.00 lb.

## 1 1/2" HOSE CONNECTORS

Hose connectors are designed for connecting hose to a wand, wall handle, or directly to a tool with a knurled locking nut.

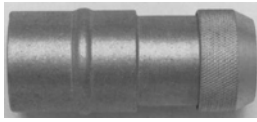

**ALUMINUM STRAIGHT** – With locking nut.

**VTL90078**  
(189)  
.50 lb.



**ALUMINUM STRAIGHT** –  
With shut-off valve and locking nut.

**VTL90079**  
(890)  
.88 lb.

## 1 1/2" ELBOW CONNECTOR

45° elbow connector for connecting hose to wand or floor handle.



**NICKEL PLATED MALLEABLE IRON** –  
With aluminum swivel and locking nut.

**EVT90004**  
(2295)  
1.13 lb.

## 1 1/2" FLOOR ELBOW

90° elbow for connecting hose to floor valves (VLV90110, VLV90112, VLV90227, VLV90246, VLV90233, VLV90237 or equivalent lock-type valve). Eliminates hose strain and allows for 360° swivel.

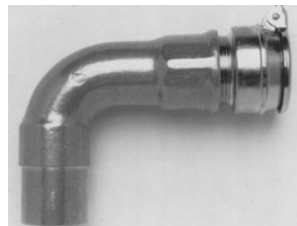

**ALUMINUM** – Equipped with inlet valve  
VLV90082 (Type "B").

**EVT90005**  
(1325)  
1.75 lb.

## 2" EQUIPMENT

All 2" equipment is designed for extra heavy duty industrial service where large accumulations of dirt and litter are encountered.

Replacement part numbers are listed in blue italic.

\*Quantity (2) required.

### TOOLS



**5" GULPER** – Aluminum. Fits directly into female coupling for large accumulation of material.

**VTL90048**  
(1835)  
2.25 lb.



**5" GULPER** – Aluminum. Permanently attached to chrome plated steel wand. Connects directly into 2" Female Hose Coupling.

**VTL90049**  
(1836)  
5.50 lb.



**15" BARE FLOOR** – Steel sides. To be used at the end of a wand. For scraping or severe service or rough abrasive floors.

*\*Replacement side*

**VTL90057**  
(2030)  
2.75 lb.  
*SVT90011*



**15" BARE FLOOR** – Rubberized sides. To be used at the end of a wand. For unfinished wood floors or rough surface. Also used for liquid removal.

*\*Replacement side*

**VTL90058**  
(1240)  
2.38 lb.  
*SVT90018*

### WAND



**52" CHROME PLATED** – Steel. To be used with 2" elbow connector (VTL90072) and 2" tools.

**HDL90039**  
(1225)  
3.25 lb.

### ELBOW CONNECTOR



**45° ELBOW CONNECTOR** – For connecting hose to a wand. Nickel-plated aluminum with hose swivel and locking nut.

**VTL90072**  
(1875)  
1.38 lb.

### HOSE ADAPTERS

1 1/2"



2"

**HOSE ADAPTER** – Allows 2" hose to connect to a 1 1/2" inlet valve or 2" tool set to connect to a 1 1/2" I.D. hose.

**VTL90082**  
(1850)  
.75 lb.

2"



1 1/2"

**HOSE ADAPTER** – Allows 1 1/2" hose to connect to a VLV90100 or 1 1/2" tool set to connect to a 2" I.D. hose.

**VTL90073**  
(1957)  
.88 lb.

# HOSE

Consider the application, the size and service requirements when selecting a hose.

**1 1/4"** I.D. hose is recommended for light commercial duty. It is lightest in weight and with superior flexibility.

**1 1/2"** I.D. hose is the most common and used for average vacuum cleaning applications.







**2"** I.D. hose is recommended for large quantities or bulky materials.

**Note:** For other diameter hose or special applications — consult factory.

Both the **1 1/4"** and **1 1/2"** I.D. hoses are used with our **1 1/2"** attachments. **2"** I.D. hose is used with **2"** attachments.

Hoses are supplied with one male and one female coupling. The male coupling connects into the inlet valve; the female coupling connects directly to tools or attachments. Hoses may be joined for additional length using the standard male and female couplings.

**HOSE ASSEMBLIES (EXCEPT TUFF-FLEX AND YELLOW CAR CARE PRODUCTS) ARE TESTED FOR ELECTRICAL CONDUCTIVITY TO ASSURE STATIC ELECTRICITY IS MINIMIZED.**

Hose Type	Inside Diameter	Lengths and Part Numbers			
		12 1/2'	25'	37 1/2'	50'
Light-Duty PVC 	1 1/2"	HOS90164	HOS90166	HOS90168	HOS90170
	2"	HOS90176	HOS90178	HOS90180	HOS90182
Medium-Duty Polyethylene "TUFF-FLEX" NON STATIC RESISTANT 	1 1/4"	HOS90081	HOS90082	HOS90212	HOS90083
	1 1/2"	HOS90077	HOS90078	HOS90079	HOS90080
	2"	HOS90084	HOS90085	HOS90086	HOS90087
	1 1/2"	HOS90088	HOS90089	HOS90090	HOS90091
Heavy-Duty PVC 	1 1/2"	HOS90188	HOS90190	HOS90192	HOS90194
	2"	HOS90200	HOS90202	HOS90204	HOS90206
Heavy-Duty Urethane "SPENCER-FLEX" 	1 1/2"	HOS90241	HOS90243	HOS90245	HOS90247
Heavy-Duty Vinyl "PYTHON" 	1 1/2"	HOS90101	HOS90103	HOS90105	HOS90107
	2"	HOS90109	HOS90111	HOS90113	HOS90115
Heavy-Duty Rubber "RHINO" 	1 1/2"	HOS90117	HOS90119	HOS90208	HOS90121
	2"	HOS90123	HOS90125	HOS90210	HOS90127



## CAR CARE KIT

### KAC90104

Convenient all-in-one operator package with 15' long, 1 1/2" diameter yellow plastic hose, coupling, duck foot cleaning tool and tool holder.

### KAC90108

Same as above with static resistant hose.  
*Replacement rubber backing RUB90001*

Weight (lbs./ft.)	Vacuum Rating "Hg	Color	Flexibility	Durability	Application	Construction
.26	26	Grey	Excellent	Fair	Commercial, Light Industrial Duty, Offices (Temp Range: -20° to +150°F)	Fiber-reinforced PVC Hose Cover Spring Steel Helix Static Resistant
.37	25	Grey	Excellent	Fair		
.28	25	Grey	Excellent	Good	General Vacuum Cleaning, Commercial, Car Wash, Offices (Temp Range: -20° to +150°F)	Polyethylene Two-Piece Construction Crush Proof
.41	20	Blue	Excellent	Good		
.50	12	Blue	Excellent	Good		
.41	20	Orange	Excellent	Good		
.40	28	Blue	Good	Very Good	General Service, Schools, Industrial Cleaning (Temp Range: -22° to +104°F)	PVC Compound Plastic Helix Copper Ground Wire Abrasion Resistant Static Resistant
.50	28	Blue	Good	Very Good		
.32	24	Blue w/ Black	Very Good	Excellent	General Service, Industrial Cleaning, Schools (Temp Range: -40° to +170°F)	PVC Helix Urethane Core Abrasion Resistant Copper Ground Wire Chemical Resistant Static Resistant
.50	29.8	Blue	Very Good	Very Good	General Service, Schools, Hospitals, Clean Rooms (Temp Range: -20° to +120°F)	Smooth Vinyl Cover Steel Wire Nylon Yarn Foam Inner Wall Chemical Resistant Static Resistant
.60	29.8	Blue	Very Good	Very Good		
.7	28	Black	Good	Excellent	Industrial and Heavy Commercial Vacuum Cleaning in Factories, Foundries (Temp Range: -40° to +200°F)	Braided SS Ground Wire Nitrile Rubber Tube Abrasion Resistant Neoprene Cover Oil Resistant Static Resistant
.9	28	Black	Good	Excellent		

# WALL INLET VALVES FOR 1½" DIAMETER HOSE

Inlet valves provide a quick connection of the male hose coupling to the piping system or separator. The cover is self-closing and includes a hook to prevent the hose from being pulled out. Valve bodies are forged brass, covers are steel, and the entire valve is nickel plated.

Four basic valves are available. Each may be fitted with a standard or recessed escutcheon plate. The basic valves are used with exposed piping in basements, on concrete walls, in factories or on separators.

The standard wall flange is recommended for most typical installations. Valve protrusion into the room is only 1 inch. Furthermore, the face of the threaded connection can be as little as 13/16 of an inch from the wall — advantageous where space is limited.

The recessed flange is recommended for areas using flush wall design. It is considered a more attractive installation.

Optimum mounting height of wall valves is 18 to 20 inches above floor level. **NOTE: Optional lock type covers are available.**



2" male thread-exposed pipe. The popular (standard) valve. 2 1/32" long.

**VLV90083** (8720-Type E) **(VLV90091 Lock Type)**  
1.13 lb.



2" female thread-exposed pipe. 2 1/32" long.

**VLV90101** (8815-Type E) **(VLV90102 Lock Type)**  
1.50 lb.



2" male thread VLV90083 with "standard" flange.

**VLV90084** (8705-Type D) **(VLV90093 Lock Type)**  
1.50 lb.



2" female thread VLV90101 with "standard" flange.

**VLV90103** (8805-Type D) **(VLV90104 Lock Type)**  
1.78 lb.



2" male thread VLV90083 with "recessed" flange.

**VLV90085** (8705A-Type DA) **(VLV90095 Lock Type)**  
1.63 lb.



2" female thread VLV90101 with "recessed" flange.

**VLV90105** (8810A-Type DA) **(VLV90106 Lock Type)**  
1.75 lb.



2" male thread-exposed pipe with short body. 1 7/8" long.

**VLV90087** (8730-Type E) **(VLV90092 Lock Type)**  
1.00 lb.



1½" male thread-exposed pipe. Use when a 1½" thread must be used. 2 7/16" long.

**VLV90082** (8740-Type B) **(VLV90090 Lock Type)**  
1.13 lb.



2" male thread VLV90087 with "standard" flange. For limited wall space.

**VLV90088** (8715-Type D) **(VLV90094 Lock Type)**  
1.25 lb.



1½" male thread VLV90082 with "standard" flange.

**VLV90089** (8745-Type C) **(VLV90097 Lock Type)**  
1.25 lb.



2" male thread VLV90087 with "recessed" flange. For limited wall space.

**VLV90086** (8715A-Type DA) **(VLV90096 Lock Type)**  
1.25 lb.



1½" male thread VLV90082 with "recessed" flange.

**VLV90098** (8745A-Type CA) **(VLV90099 Lock Type)**  
1.25 lb.



304SS version of an 8720 Type E inlet valve with 2" male thread valve.

**VLV90239** 1.13 lb.



304SS "recessed" flange to fit VLV90239.  
**FLG90024** 0.3 lb.

304SS "standard" flange to fit VLV90239 (Not Shown).

**FLG90025** 0.2 lb.



## FLOOR INLET VALVES FOR 1½" DIAMETER HOSE

When it is inconvenient to use wall valves, floor valves are available. The valve is made of forged brass with a natural brush finish. It is designed to maintain its original appearance even in heavy

traffic areas. **It is recommended that the hose be connected to these valves using a Part No. EVT90005 floor elbow.**



2" male thread – Installed flush with floor surface.

**VLV90110 (VLV90111 Lock Type)**  
(8900-Type G) 1.88 lb.

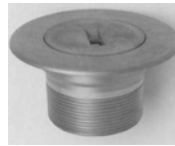

2" male thread – Beveled edge designed for use with carpets.

**VLV90112 (VLV90113 Lock Type)**  
(8905-Type R) 1.88 lb.

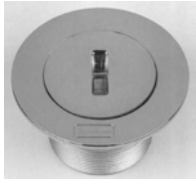

Chrome plated version of a VLV90110 Type G floor valve.

**VLV90246** 1.9 lb.

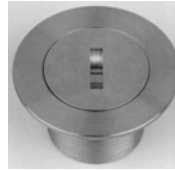

304SS version of a VLV90110 Type G floor valve.

**VLV90227** 1.9 lb.

## LOCKING VALVES



Optional lock type covers can be furnished on all wall and floor inlet valves designed for use with 1½" diameter hose.

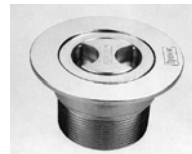

"Easy-Lift" keyless floor valve.

**VLV90449**  
Complete valve (chrome body with aluminum cover/lid)

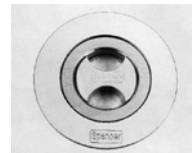

**LIV90036**  
Aluminum cover/lid only (replacement for existing valves)

## INLET VALVES FOR 2" DIAMETER HOSE OR LARGER

The 2" valve body is forged brass. The cover is steel and the entire valve is nickel plated. 2 1/2" and larger valve bodies are carbon steel. The covers are forged brass and the entire body is nickel plated.



2" male thread-exposed pipe. Accepts 2" male hose coupling.

**VLV90100**  
(8755-Type I) 1.25 lb.

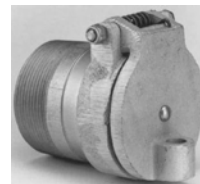

3" male thread-exposed pipe. Accepts 3" male hose coupling.

**VLV90108**  
(8675-Type L) 4.25 lb.

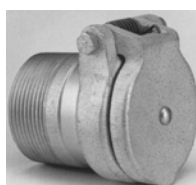

2½" male thread-exposed pipe. Accepts 2½" male hose coupling.

**VLV90107**  
(8690-Type J) 2.75 lb.

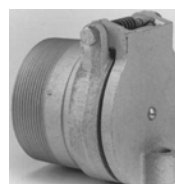

4" male thread-exposed pipe. Accepts 4" male hose coupling.

**VLV90109**  
(8676-Type K) 6.25 lb.

5", 6" and 8" inlet valves are also available.

## SILENT VALVE

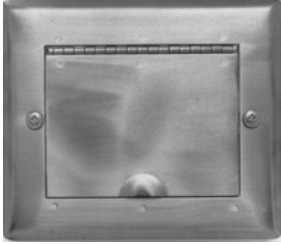

This valve is designed for use with 1½" diameter hose to minimize noise when the hose is either being inserted or removed. It is therefore ideal for use in hospitals, rest homes, libraries, dormitories and schools to control noise level.

The flush mounting is especially desirable in hospital corridors where there is a heavy stretcher and wheelchair traffic.

**VLV90115**  
(8910)  
3.50 lb.

## VACUSLOT FLOOR VALVES

A unique cleaning system is available wherever dry mops or push brooms are used. Spencer provides a floor slot that collects dirt accumulations and sweepings, as well as cleaning the mop itself. Dirt and litter pushed near the slot are carried by vacuum, through a tube system into a collector.

The convenience of a central vacuum cleaning system is available if the vacuslots are equipped with valves for hose connections.

Vacuslots are designed for flush floor installations. They are made of heavy aluminum plate with a burnished finish.

Vacuslots are ideally suited for schools, hospitals, offices, or any building with smooth floor coverings.

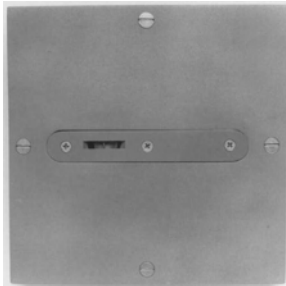

**Square Style—**  
Dry mop slot only.

**VLV90231**  
(2785-Type F)  
13 lb.

Lock  
**VLV90232**

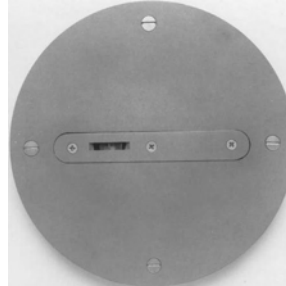

**Round Style—**  
Dry mop slot only.

**VLV90235**  
(2786-Type FR)  
13 lb.

Lock  
**VLV90236**

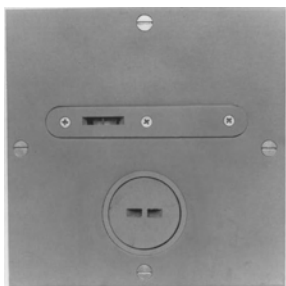

**Square Style—**  
Dry mop with valve.  
Accepts 1½" male  
hose coupling.

**VLV90233**  
(2821-Type FG)  
13 lb.

Lock  
**VLV90234**



**Round Style—**  
Dry mop with valve.  
Accepts 1½" male  
hose coupling.

**VLV90237**  
(2820-Type FGR)  
13 lb.

Lock  
**VLV90238**

## VALVE INSTALLATION TOOL



**WRN90000**

This tool is designed to fit directly into the body of a Spencer wall or floor inlet valve for 1½" or 2" hose. The opposite end of the tool may be gripped with a wrench, thereby allowing the installer to easily thread the valve into the piping system. Cast iron. 2 lb.

# ACCESSORIES



## HOSE AND TOOL CABINET

Steel compartment for storing hose and tools. Dimensions: 24" x 24" x 72", mounted on 5" legs.

### VTL90083

(2370)

175 lb.

*(shown with optional hose and tools.)*

## HOSE RACKS

For storage of hose.



### Cast Aluminum –

Wall mount

### RKV90000

(2360) 3 lb. (19<sup>3</sup>/<sub>4</sub>" x 6")

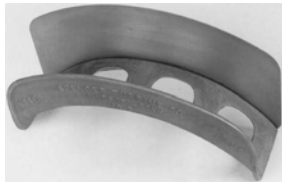

### Cast Aluminum – Column

mount with backing plate

### RKV90002

(2359) 3.25 lb. (19<sup>3</sup>/<sub>4</sub>" x 6")



### Cast Aluminum –

Wall mount-Double

### RKV90003

(2361) 6 lb. (19<sup>3</sup>/<sub>4</sub>" x 12")

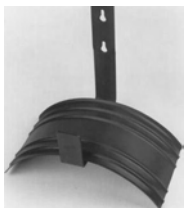

### Sheet Steel

### RKV90001

1.75 lb. (9" x 6")



### 304 Stainless Steel

### RKV90007

4.75 lb. (16<sup>1</sup>/<sub>2</sub>" x 6<sup>1</sup>/<sub>4</sub>" )

## TOOL HANGER

Steel and neoprene. Combines tool storage and vacuum shut-off for cast aluminum 6" hand tool. Bleed orifice available.

### RKV90004

(1787)

2.75 lb.

### RKV90005

(with bleed orifice)

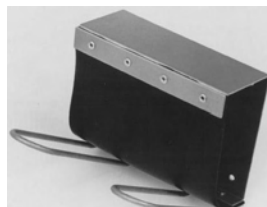

## HOSE AND TOOL CART

Steel construction with wheels includes hose rack, 10 tool holding positions, tool bin and storage tray.

Dimensions: 30<sup>1</sup>/<sub>4</sub>" wide, 49<sup>3</sup>/<sub>8</sub>" high and 31<sup>5</sup>/<sub>8</sub>" long.

### RKV90011

115 lb.

*(shown with optional hose and tools.)*



## HOSE REPAIR COUPLINGS



1<sup>1</sup>/<sub>2</sub>" female hose repair coupling for 1<sup>1</sup>/<sub>4</sub>" hose

### CPL90188

(1101)

.47 lb.

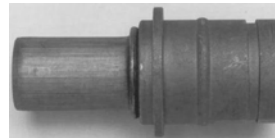

1<sup>1</sup>/<sub>2</sub>" male hose repair coupling for 1<sup>1</sup>/<sub>4</sub>" hose

### CPL90193

(1102)

.41 lb.



1<sup>1</sup>/<sub>2</sub>" female hose repair coupling for 1<sup>1</sup>/<sub>2</sub>" hose

### CPL90244

(1001)

.47 lb.

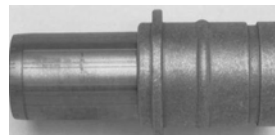

1<sup>1</sup>/<sub>2</sub>" male hose repair coupling for 1<sup>1</sup>/<sub>2</sub>" hose

### CPL90191

(1003)

.41 lb.

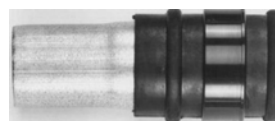

2" female hose repair coupling for 2" hose

### CPL90189

(1002)

.75 lb.

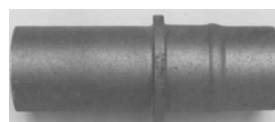

2" male hose repair coupling for 2" hose

### CPL30056

(2723C)

.625 lb.



# Spencer<sup>®</sup>

## Products & Services

### Industrially rated products offering effective solutions for air and gas moving problems:

- Multistage centrifugal blowers
- Single stage centrifugal blowers
- Gas boosters & hermetic gas boosters
- Regenerative blowers
- Modular central vacuum systems
- Mobile or stationary integrated vacuum units
- Custom-engineered products with special materials for extreme temperatures and pressures

### Complementary accessories with single source convenience and compatibility:

- Standard and custom electrical control panels — UL, CUL Listed and CE available
- Comprehensive selection of tubing, fittings, vacuum hoses, valves and tools
- Valves, gauges, couplings, shrink sleeves, vibration isolators and other system components

### Comprehensive engineering and other customer support services:

- The industry's largest complement of technical specialists in air and gas moving technology
- Worldwide parts and service organization
- Application research and testing facility
- Product selection process aided by internal computer programs

### Worldwide organization of sales representatives and distributors offering:

- Product selection, installation and operation assistance
- Comprehensive system design services
- Follow-up services and troubleshooting

For the name and telephone number of your local  
Spencer Representative, call 800-232-4321  
or email [marketing@spencer-air.com](mailto:marketing@spencer-air.com)

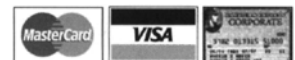

Visa, MasterCard and  
American Express welcome

The  **Spencer** Turbine Company, 600 Day Hill Road, Windsor, CT 06095-4706  
TEL 800-232-4321 ♦ 860-688-8361 ♦ FAX 860-688-0098 ♦ [www.spencerturbine.com](http://www.spencerturbine.com)

*Blowers & Vacuum Systems with an Engineering Edge*